



VERSION 1.0

WWW.PRG.COM

PRG SmartXcan

Quick Start Guide

AutoPar®, Bad Boy®, Best Boy®, Followspot Controller™, GroundControl™, Mbox®, Mini Node™, Nocturne®, Series 400®, Remote Followspot System™, ReNEW®, Super Node™, UV Bullet™, V476®, V676®, Virtuoso®, and White Light Bullet™, are trademarks of Production Resource Group, L.L.C., registered in the U.S. and other countries.

All other brand names which may be mentioned in this manual are trademarks or registered trademarks of their respective companies.

This manual is for informational use only and is subject to change without notice. Please check www.prg.com for the latest version.

PRG assumes no responsibility or liability for any claims resulting from errors or inaccuracies that may appear in this manual.

PRG SmartXcan™ Quick Start Guide

Version as of: 20 July 2020

PRG part number: AAE-8312

Production Resource Group, L.L.C.

Dallas Office

3110 Roy Orr Blvd Suite 200

Grand Prairie, TX 75050 USA

www.prg.com

Introduction

Use this Quick Start Guide to quickly set up and understand the major components of the **SmartXcan Mobile Pedestal**. It is critical to review these materials to ensure proper usage of the device.

For further details, refer to the [SmartXcan User Manual](#).

Environmental Conditions

The SmartXcan requires specific environmental conditions for accurate temperature readings. Use in a space with controlled environmental conditions.

- + Ideal 64 - 75°F / 18 - 24°C
- + Relative non-condensing humidity 10-75%
- + Do not place next to a heat source
- + The thermal image sensor should not be aimed at any other temperature source such as a incandescent light source, radiator, or A/C system
- + Do not point at the sun or open sky

Acclimation (Warmup) Period

The Unit requires one minute to start up and an estimated acclimation period of 15 minutes. This acclimation period allows the temperature scanning instrumentation to neutralize to the environment. The SmartXcan is set to allow temperature scans before the acclimation period is completed, but temperature accuracy can be affected.

If the unit is moved after the initial acclimation period, the device should be allowed to re-acclimate for at least 15 minutes before performing additional temperature measurements.

SmartXcan Mobile Pedestal

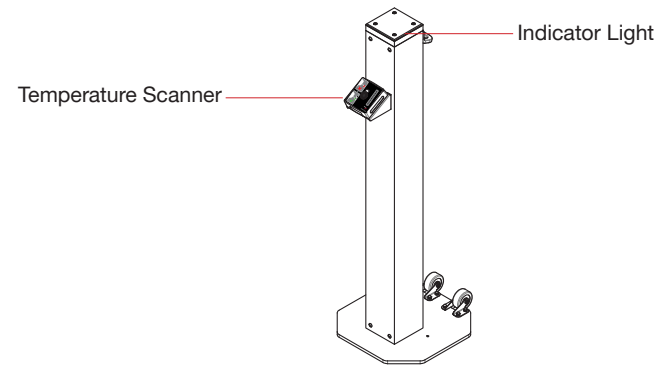

Accessories

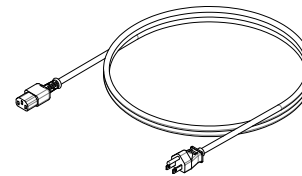

Power Cable (IEC C13)

Varies based on country of use

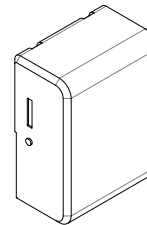

Battery, 14.8V 98Wh

See Batteries Spec on page 7.

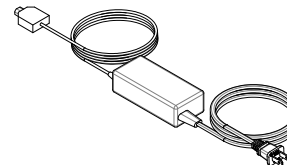

Battery Charger, Travel Verison

See User Manual for charging information.

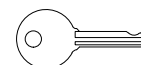

Battery Compartment Key (x2)

Temperature Scanner Unit Detail

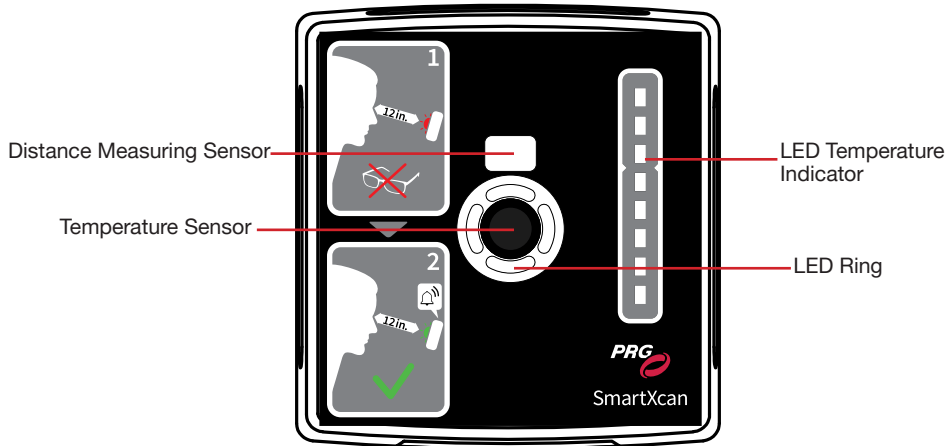

SmartXcan Scanning Unit

LED Temperature Indicator Scale

By default, the acceptable temperature ranges are shown below in Figure 4. The temperature ranges can be changed from the SmartXcan web interface.

The CDC states a fever to be any temperature of 100.4°F or above.

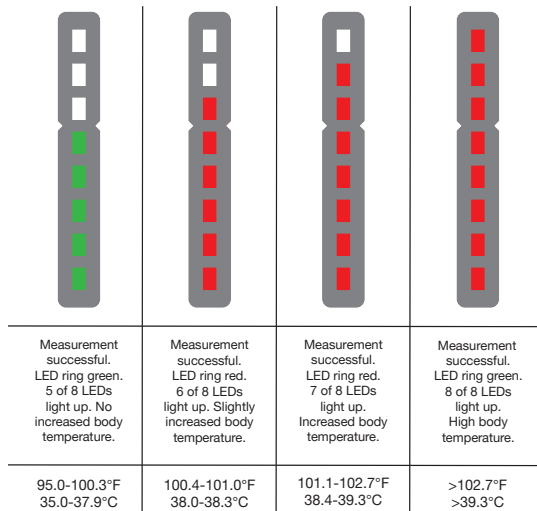

LED Temperature Scale Breakdown

Securing Unit

The SmartXcan unit must be secured to ensure it will remain upright.

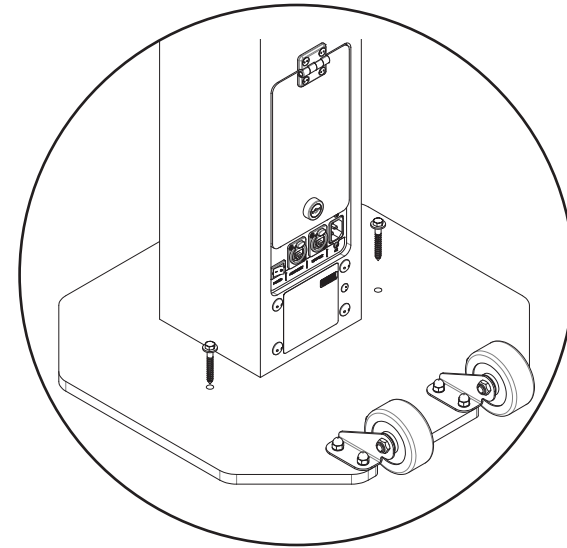

SmartXcan Base Mounting

Secure unit with two fasteners (Ø1/4" max). Each shall have a minimum tensile capacity of 200 lbf.

Each fastener shall have sufficient embedment depth to withstand 200 lbf of tension.

Connecting Power

AC Power

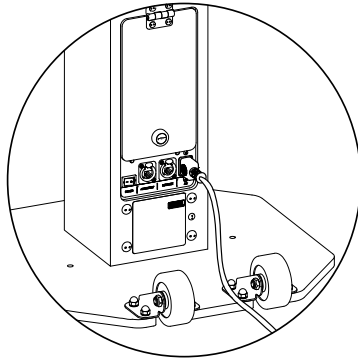

Connect the unit to a grounded AC power source of 100-240V 50/60Hz.

Note: The battery does not charge when the SmartXcan is connected to AC power.

Battery Power

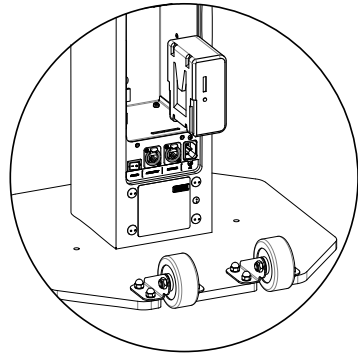

Step 1. Unlock the battery door on the rear of the unit.

Step 2. Install a charged battery onto the battery mounting plate by sliding the battery downwards onto a charging bay. Ensure the V-Mount rails are aligned between the charger and battery.

Step 3. The battery is fully engaged when the latch makes an audible “click” sound and is firmly seated.

PoE

See the [SmartXcan User Manual](#) for connecting to a PoE source.

Operating Modes

Standalone

The SmartXcan device will operate as-is without any additional network or computer connections. This is the most simple and common operating mode.

Networked

Optionally, the user may choose to connect the device to a single computer or a computer network to perform any of the following (but not limited to):

- + Enable a simple Kiosk (monitoring) mode
- + Configure the device
- + For additional features, refer to the [SmartXcan User Manual](#)

Accessing SmartXcan Web Interface

Use the following steps to access the SmartXcan web interface

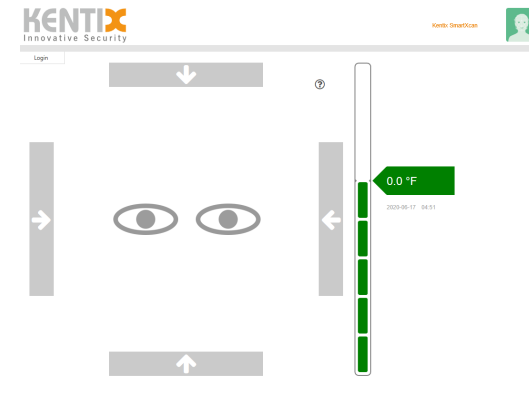

SmartXcan Web Interface Kiosk Window

Step 1. Set the IP address of the computer you wish to connect the SmartXcan as stated below. Computer IP Address: 192.168.100.101
Subnet Mask: 255.255.255.0

Step 2. It is recommended to disable all other network sources of the computer such as WiFi. Any firewalls should also be disabled.

Step 3. Open a web browser window and type in the IP address 192.168.100.223

Refer to the [SmartXcan User Manual](#) for login and configuration information.

Temperature Scanning Procedure

1  **Approach** the SmartXcan Mobile Pedestal

2  **Position** face about 12 inches from the scanner

3  **Identify** the center of the temperature scanner. The ring will illuminate green once in the measurement zone.

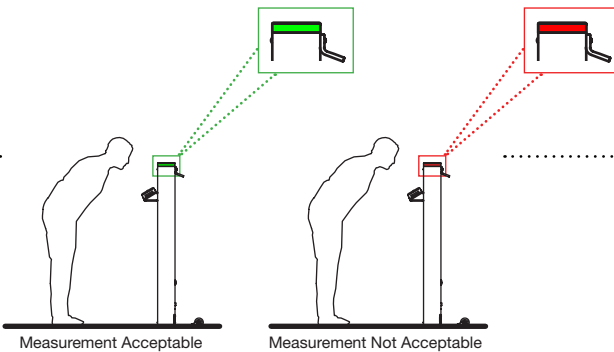
4  **Observe** the illumination of the indicator light and audible sound confirming scanner completion.

Measurement Acceptable Measurement Not Acceptable

Battery Specs

Shape Full Play 14.8V 98Wh Rechargeable Lithium-Ion V-Mount

Rated Battery Usage

- + Scanner only: 54.3 hours
- + Scanner & Indicator Light: 38.0 hours (700 scans per hour)
- + Scanner & Indicator Light: 52.8 hours (average of 50 scans per hour)
- + Estimated Battery Lifetime: 3.3 years (continuous use)

Transport: Safe for air travel (IATA approved) Ensure proper markings on box according to company policy and local ordinances.

Refer to the SmartXcan User Manual for information on other compatible batteries.

Cleaning

To clean the SmartXcan body and mobile pedestal, use a non-abrasive disinfectant such as a 10:1 Bleach Mixture or other disinfectant wipe. Use extra care not to soak the temperature probe.

To clean the SmartXcan probe, use electronics-safe and oil-free compressed air. Do not stick any object into the probe. A dry or lightly-damped microfiber cleaning cloth can also be used to clean the probes/lenses.

Support & Questions

Have you referred to the [SmartXcan User Manual](#)?

Information Page: prg.pub/SmartXcan

Client Support: SmartXcanSupport@prg.com

Technical Specs

- + Mains : 100-240V \pm 10%, 50/60 Hz, 0.5A Max
- + PoE : 37- 44VDC, 0.35A PoE Type 1 (See User Manual for connection information)
- + Battery ; 14.8VDC, 1.0A
- + Operating Ranges: 18°C to 24°C, 10-75% non-condensing humidity
- + IEC 60320 C14 Power-In
- + Battery or PoE optional
- + Two Neutrik® etherCON ports
- + On/Off Switch
- + Infrared thermal array thermal sensor
- + Laser IEC 60825-1:2014-3, Class 1 distance sensor
- + Scan distance of 4-12in (10-30cm)
- + Scan Time, Throughput: 0.6 second scan time (5 seconds for approach, scan, departure)
- + 700 temperature measurements per hour
- + Mobile pedestal, turnstile access
- + lack powdered coated aluminum (others upon request)
- + Integrated buzzer and LED indicator
- + Web Interface Configuration Software
- + Room temperature sensor: Measuring range 0 to 85 °C (accuracy \pm 0.5 °C)
- + Air humidity sensor: Measuring range 0 to 100 % (accuracy \pm 3 %)
- + Infrared sensor: Measuring range 0-100 °C, repeatability \pm 0.3 °C, resolution 0.1 °C, emission factor 0.98, ambient temperature 18 - 28 °C
- + External connections
- + REST API supporting plain text, JSON, or XML content types via POST or GET methods
- + Monitoring, notifications, and alerts via SNMP and SMTP
- + Integrated webserver with onboard management and configuration
- + Integration with Kentix AlarmPro software
- + Maximum Altitude: Normal 2000m
- + Overvoltage Category: Normal II
- + Pollution Degree: Normal 2
- + IP30
- + 55.75" H x 18" W x 19.4" L (1416mm x 457mm x 492mm)
- + Weight: 69lbs. (31.3kg)
- + ETL/CE Certified (Pending)

Compliance

This device complies with Part 15 of the FCC rules. Operation is subject to the following two conditions:

- 1) This device may not cause harmful interference, and
- 2) This device must accept any interference received, including interference that may cause undesired operation.

Conforms to:

UL STD 1573

PENDING CERTIFICATION to:

CAN/CSA STD E598-1

CAN/CSA STD E598-2-17

Important Safety Instructions

- + Read these instructions.
- + Keep these instructions.
- + Heed all warnings.
- + Follow all instructions.
- + Not to be used in any other way not specified by the manufacturer.
- + Do not use this apparatus near water.
- + Use caution when cleaning.
- + Do not install near any heat sources such as radiators, heat registers, stoves, or other apparatus (including amplifiers) that produce heat.
- + Protect the power cord from being walked on or pinched, particularly at plugs, convenience receptacles, and the point where they exit from the apparatus.
- + Unplug this apparatus during lightning storms or when unused for long periods of time.
- + Refer all servicing to qualified service personnel. Servicing is required when the apparatus has been damaged in any way, such as power-supply cord or plug is damaged, input ports are damaged, liquid has been spilled or objects have fallen into the apparatus, the apparatus has been exposed to rain or moisture, does not operate normally, or has been dropped.
- + In Europe: The building installation shall be regarded as providing protection in accordance with the rating of the wall socket outlet.
- + In Finland: Laite on liitettävä suojamaadoituskoskettimilla varustettuun pistorasiaan.
- + In Norway: Apparatet må tilkoples jordet stikkontakt.
- + In Sweden: Apparaten skall anslutas till jordat uttag.
- + No naked flame sources should be placed on the apparatus.
- + Apparatus not for use in tropical climates.
- + The apparatus shall not be exposed to dripping or splashing. No objects filled with liquids, such as vases, shall be placed on the apparatus.

Medical Disclosure

This manual is not intended to define any policy or procedures.

The SmartXcan is not a medical thermometer. It shall not be utilized as a substitute for an examination by a medical professional. A medical examination is always necessary to determine a subject's exact temperature.

The PRG SmartXcan is NOT a product intended for use in the diagnosis of disease or other conditions or in the cure, mitigation, treatment, or prevention of disease; the device is not covered under section 201(h) of the FD&C Act (21 U.S.C. 321(h)).

The measurement should not be solely or primarily relied upon to diagnose or exclude a diagnosis of COVID-19, or any other disease.

- a) Elevated body temperature in the context of use should be confirmed with secondary evaluation methods (e.g., an NCIT or clinical grade contact thermometer)
- b) Public health officials, through their experience with the device in the particular environment of use, should determine the significance of any fever or elevated temperature based on the skin telethermographic temperature measurement;
- c) The technology should be used to measure only one subject's temperature at a time
- d) Visible thermal patterns are only intended for locating the points from which to extract the thermal measurement.

This temperature measuring device meets the (IEC 80601-2-59;2017) standard relating to requirements for safety and essential performance of screening thermographs.

Electrical Safety

WARNING! For personal safety, this equipment must be properly grounded when connected to an AC power source.

Do not, under any circumstances, cut or remove the ground prong from the power cord.

The power cord of this equipment is shall be minimum 18AWG with a grounding plug that mates with a grounded outlet to minimize the possibility of electric shock hazard from this equipment.

The plug that mates to the outlet shall be compatible with the country standards the product shall be used in. The connector mating to the device's C14 inlet will be an IEC 60320 C13 connector.

Ensure the outlet that the device will be connected to is properly grounded. NEVER use a ground lift or any other device which would not connect the device to ground.